

TMK272

**SHADOW FORD DN9b
"Samson Shag"**

BELGIAN G.P. 1979

Manufactured under Licence from
"SHADOW MARQUE Service"



HOW TO DRILL

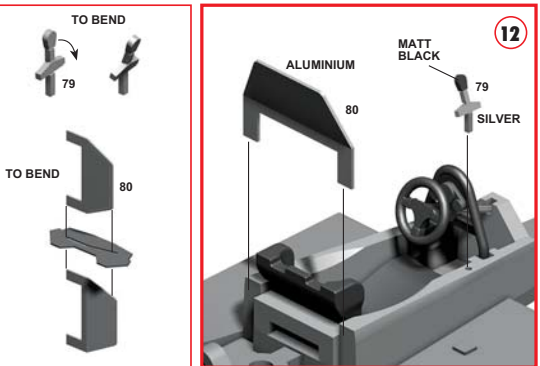
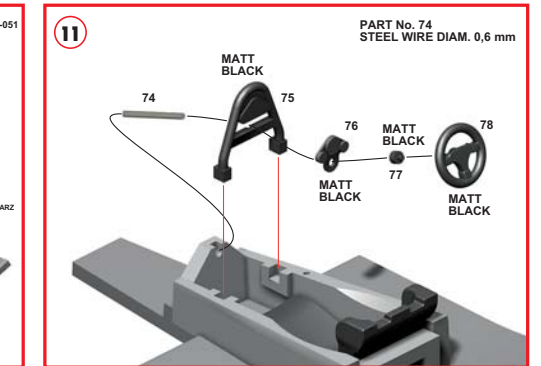
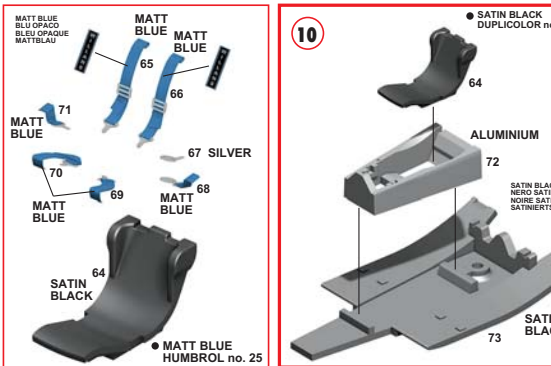
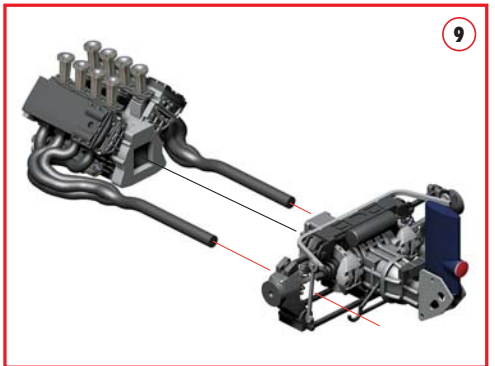
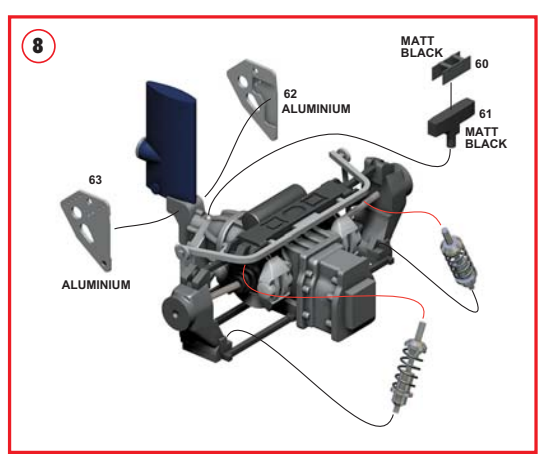
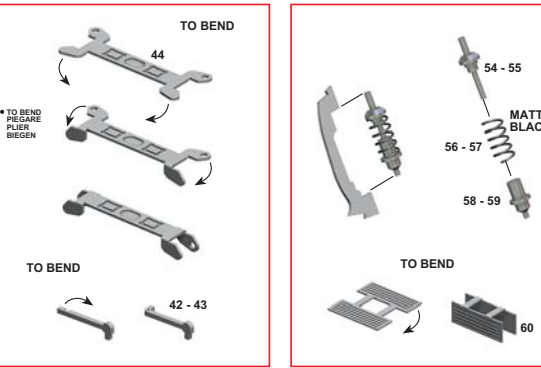
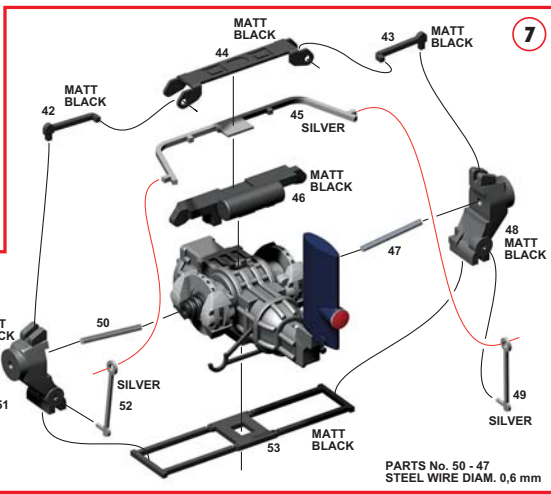
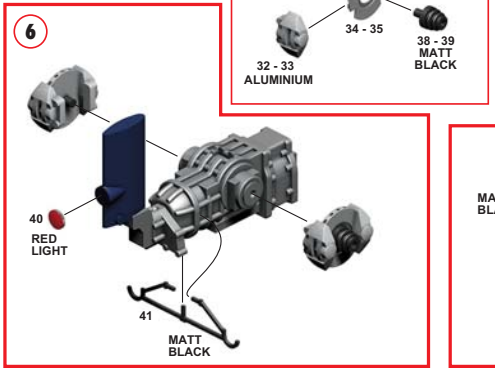
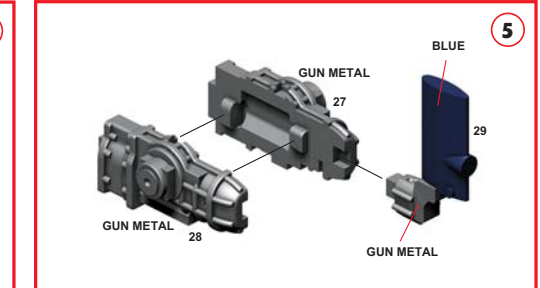
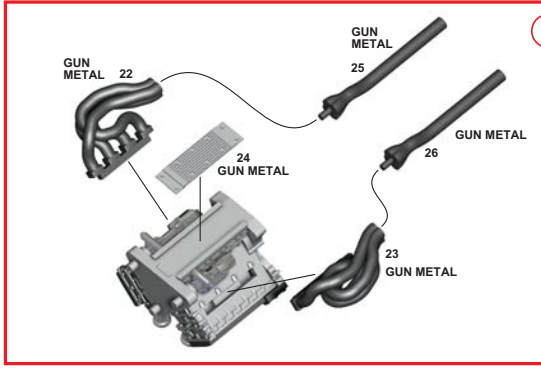
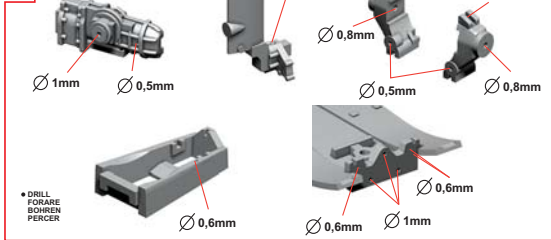
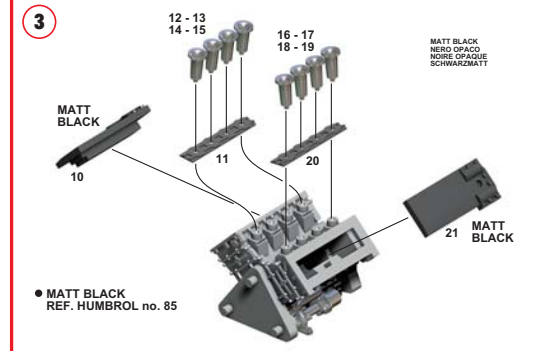
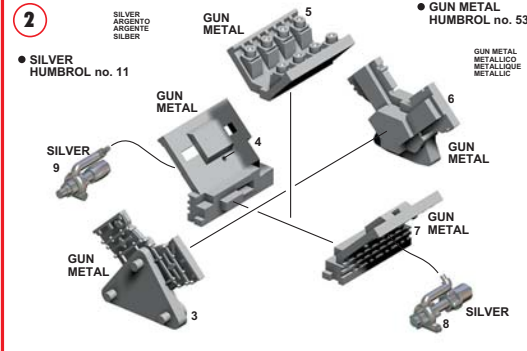
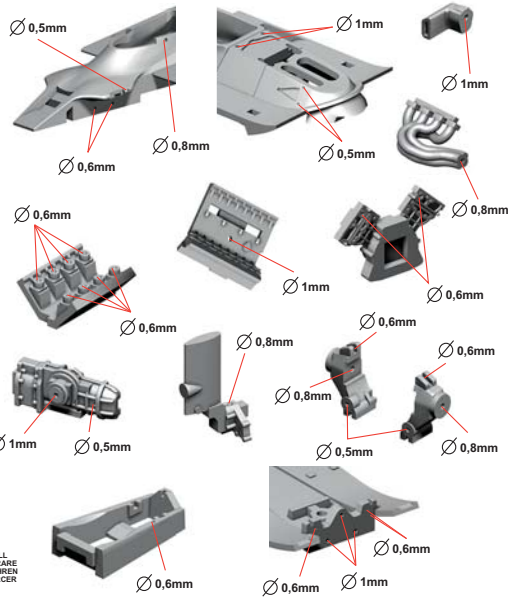

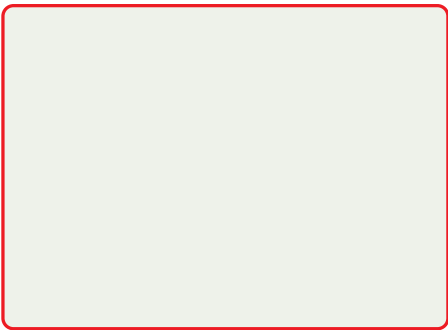

● ALUMINIUM HUMBROL no. 56

ALUMINIUM ALUMINIO ALUMINIUM ALUMINIUM

MATT BLACK 82

ALUMINIUM 83

14

MATT BLACK 84

TO BEND

85

15

SILVER 86, 87

ALUMINIUM 90

BLUE 88, 89

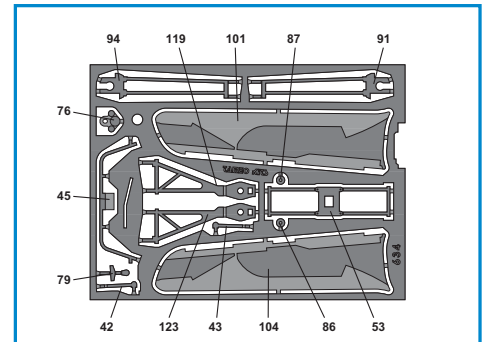

TO BEND

91 - 94

13

MATT BLACK 81

17

MATT BLACK 95, 96

BLUE DECAL

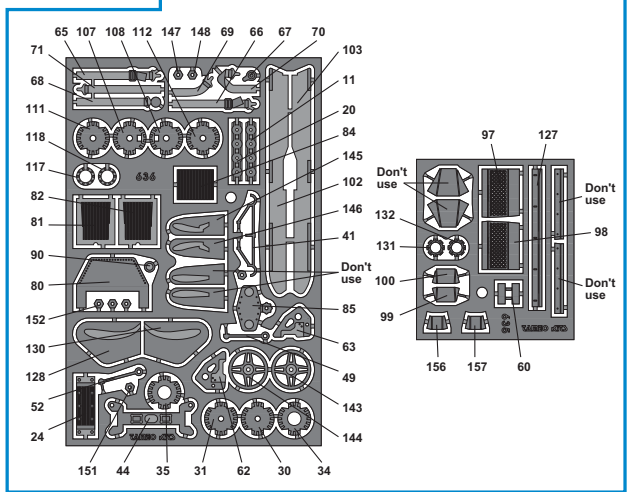

16

MATT BLACK 91, 92

ALUMINIUM 93, 94

PARTS N° 92 - 93 ALUMINIUM

POLISHED STEEL 107 - 108

ALUMINIUM 109 - 110

ALUMINIUM 111 - 112

MATT BLACK 113 - 114

ALUMINIUM 115 - 116

MATT BLACK 117 - 118

ALUMINIUM 119

TO BEND

97 - 98

TO BEND

119 - 123

19

MATT BLACK 119, 121

BLUE 120, 122

PART No. 122 STEEL WIRE DIAM. 0,4 mm

128

BLUE

127 BLUE

129 BLUE

130 BLUE

21

MATT BLACK 148, 149, 150, 151

IVORY 154, 155

BLUE 145, 146

MATT BLACK 147, 152, 153

YELLOW DECALS *156 - *157

● IVORY HUMBROL no. 41

IVORY AIVOIRO NOIR ELFENBEIN

18

SATIN BLACK 99, 100, 101, 102, 103, 104, 105

BLUE 101, 102, 103, 104

MATT BLACK 97, 98

PARTS N° 102 - 103 ALUMINIUM

20

MATT BLACK 125, 126

BLUE 123, 124

PART No. 126 STEEL WIRE DIAM. 0,4 mm

TO BEND

127

131 - 132

MATT BLACK 133 - 134

MATT BLACK 135 - 136

MATT BLACK 137 - 138

TO BEND

156 - 157

139 - 140

MATT BLACK 141 - 142

MATT BLACK 143 - 144

MONACO G.P.



TAMEO ARCHIVES

USA - WEST G.P.



TAMEO ARCHIVES

TAMEO KITS
TMK272 SHADOW FORD DN96
BELGIAN G.P. 1979

BELGIAN G.P.



TAMEO ARCHIVES

SPANISH G.P.



TAMEO ARCHIVES

TAMEO KITS srl

Via Valle, 111 - P.O. Box 61
17022 BORGIO VEREZZI SV ITALY
Tel. 39 019 - 615.250
Fax. 39 019 - 615.310

www.tameokits.com

sales@tameokits.com

technical@tameokits.com

Made in Italy. Modello per collezionisti in scala 1/43. Vietata la vendita ai minori di 14 anni. Nocivo per ingestione. Conservare fuori dalla portata dei bambini. Tameo Kits declina ogni responsabilità per un uso improprio del prodotto.

Made in Italy. Collector 1/43 Scale Models. Not for sale to persons under 14 years of age. Dangerous if swallowed. Keep out of reach of children. Tameo Kits not held responsible for any damage or injury resulting from improper use of the product.

Made in Italy. Modèle pour collectionneurs échelle 1/43. Vente interdite aux enfants de moins de 14 ans. Dangereux si avalé. Conserver hors de la portée des enfants. Tameo Kits décline toute responsabilité dans le cas de dommages dérivants de l'usage non approprié du produit.

Made in Italy. Sammlermodell im Massstab 1/43. Verkauf an Jugendliche unter 14 Jahren verboten. Schädlich bei Verschlucken. Tameo Kits lehnt jede Verantwortung bei unsachgemässer Benutzung des Produktes ab.

Hecho en Italia. Coleccion de modelos a escala 1/43. Prohibida la venta a menores de 14 años. No comestible. Mantener fuera del alcance de los niños. Tameo Kits no se hace responsable de los daños causados por el uso incorrecto de este producto.



Commento di Don Nichols
Proprietario Team Shadow

Commentaire M. Don Nichols
Propriétaire équipe Shadow

Comments from Don Nichols
Team Shadow's Proprietor

La Shadow DN9A, versione 1978, di Hans Stuck/Clay Regazzoni si è classificata per tre volte al quinto posto nei Gran Premi. La Arrows FA1, "un clone della Shadow DN9A", la cui progettazione era fondamentalmente identica a quella dell'altra vettura, pilotata da Riccardo Patrese, ha dominato nel Gran Premio del Sudafrica fino agli ultimi giri (si è poi ritirata per rottura del motore) ed ha terminato al secondo posto nel Gran Premio di Svezia.

L'abbandono del progettista Tony Southgate ne interruppe lo sviluppo ed influi negativamente sul potenziale vincente della vettura DN9, nella stagione dei Gran Premi 1979.

Il modello Shadow DN9B del 1979, era dotato di minigonne e di nuovi dispositivi nel campo dell'effetto suolo. Fu inoltre affidata a due giovani e brillanti piloti, Jan Lammers e Elio De Angelis e a Danny Ongais, un veterano della "NHRA AA Fuel Drag Racing" e "Funnycar Champion" più volte vincitore delle corse Indycar.

Purtroppo, durante la stagione 1979 la politica della Goodyear ridusse in larga misura la fornitura dei pneumatici e la vShadow non riuscì ad ottenere gli speciali pneumatici da qualificazione, se non in rare occasioni. Questo compromise notevolmente il suo sviluppo e le sue prestazioni, nonostante gli sforzi eccezionali compiuti da Elio De Angelis. Alla fine, durante l'ultima corsa, il Gran Premio degli Stati Uniti, Elio de Angelis riuscì a conquistare un bellissimo 4° posto usando pneumatici di tipo standard. E' opinione comune che la DN9B non abbia mai potuto raggiungere il suo pieno potenziale.

La voiture Shadow DN9A, version 1978, de Hans Stuck/Clay Regazzoni a obtenu par trois fois la cinquième place dans les Grands Prix. La Arrows FA1, "un clone de la Shadow DN9A", dont la conception était pratiquement identique à celle de l'autre voiture, pilotée par Riccardo Patrese, a tenu la tête au Grand Prix d'Afrique du Sud jusqu'aux derniers tours (elle a dû se retirer parce qu'elle a fondu son moteur) et a obtenu la deuxième place au Grand Prix de Suède.

Le départ du concepteur Tony Southgate a interrompu le développement et a compromis le potentiel de réussite de la

La Shadow del 1979 è stata, probabilmente, la prima vettura di Formula Uno per la quale si è usata la verniciatura con aerografo, rivoluzionaria per quell'epoca, per disegnare il "Leone Samson", simbolo dello sponsor principale. Il risultato finale fu una vettura dal "look" eccezionale, che incorporava l'idea della velocità e del coraggio.

La vettura, affidata al giovane Jan Lammers ricco di carisma e di talento, rese il 1979 la più fantastica stagione della mia carriera, nonostante la scarsa affidabilità della vettura ed i limitati successi, dovuti al basso budget operativo di cui disponevamo.

En 1979, Shadow fût, probablement, la première voiture de Formule Un pour laquelle on utilisa la technique de peinture par aérographe, qui à l'époque était révolutionnaire, pour peindre le "Lion Samson" symbole du sponsor principal de l'équipe. Le résultat fût une voiture au "look" exceptionnel qui incarnait l'idée de la vitesse et du courage.



Commento di Jo Ramirez
Team Manager Team Shadow

Commentaire Jo Ramirez
Manager équipe Shadow en 1979

Comments from Jo Ramirez
Team Manager of Team Shadow in 1979



BELGIAN G.P. 1979



17 - Jan Lammers

10th.

